

HPV

High-pressure Profiled Ring Valve

For use under difficult conditions

HOERBIGER

Superior efficiency and temperature resistance for small-diameter valves

The HOERBIGER HPV, High-pressure Profiled Ring Valve, is especially designed for use under difficult conditions. Whether high pressure hydrogen, noble gases, bio-gas, CNG, hydrocarbons – the HPV valve covers most requirements of the chemical, pharmaceuticals and electronics industries and of renewable energy providers.

The wide range of applications includes reciprocating as well as diaphragm compressors. The HPV valve is the best choice for compressors with high-pressure ratios, high discharge temperatures and non-lube operation.

HOERBIGER HPV valve is characterized by low clearance volume and enables economical compressor design.

High-temperature valve ring

- Suitable for 300 °C operating temperature
- High-temperature PEEK
- Carbon fiber reinforced
- Impact resistance many times higher than steel plate
- Excellent chemical resistance

Profiled valve ring/seat

- Streamlined flow path optimizes the effective flow area
- Minimizes power consumption

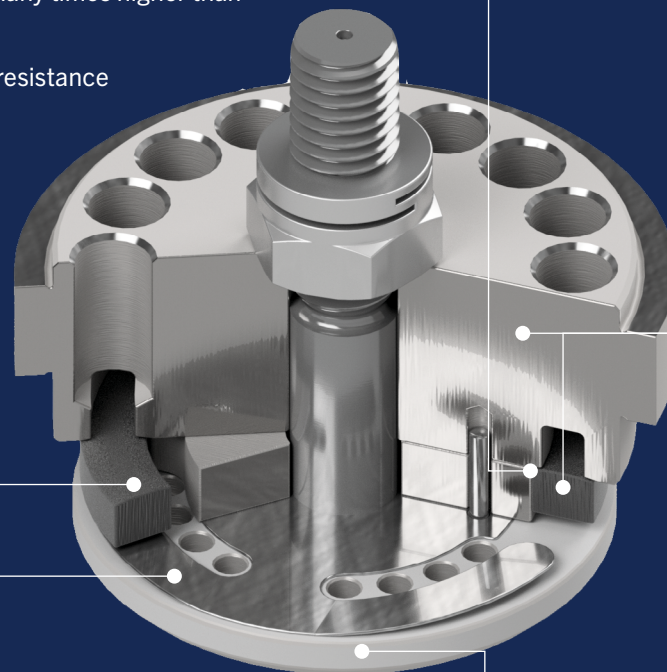

Material technology

- Tribologically optimized for non-lube operation
- Hydrogen-compatible materials

Spring technology

- Robust spring plates designed for high pressures, high-speed and precise closure
- High-purity chrome steel, especially heat treated
- Super-fine surface finish

Guard design

- Minimized clearance volume
- Safety guard optionally available

HPV valves support maximum pressures and difficult conditions

The profiled valve ring made from high-strength, high-temperature-carbon-filled PEEK stands out thanks to its extreme temperature and excellent impact resistance.

The HPV valve is specially designed to cope with medium and high pressures in confined mounting spaces.

Your benefits at a glance

| Features | Advantages | Benefits |
|---|--|--|
| Profiled ring design | Industry benchmark in efficiency for high-pressure valves: | Long life and high compressor uptime |
| Carbon fiber reinforced high-temperature PEEK | 30–40% higher effective flow area than conventional valves. Superior efficiency even at low lift. | |
| Low clearance volume | Enables high compression ratios. | Cost-effective compressor design |
| High-temperature valve ring | Suitable for high discharge temperatures. | |
| Spring plate made of high purity steel with super-fine surface finish | Designed for high dynamic loads in high-pressure and high-speed compressors | Excellent reliability |
| Hydrogen-compatible material | Resistance to hydrogen embrittlement. | Long life and safe operation in high pressure H2 compression |
| Tribological optimization | Suitable for non-lube compression | |
| Industry benchmark in efficiency. | Replace wear parts less frequently | Lower maintenance costs |
| Tribological optimization | Reduce main driver energy costs | Reduced driver power |
| Robust spring plate | | Savings in CO2 emissions |



Learn more by visiting
www.hoerbiger.com/hpv
today!



Contact us for
more information!

Locally close to the customers – globally successful: HOERBIGER is active worldwide in 43 countries on all continents. 6,174 employees at 133 locations – including 30 production plants – deliver reliable solutions for better performance, increased safety, and fewer emissions. In 2023, they generated sales of 1.416 billion euros. For renowned customers from the energy sector, the process industry, the automotive industry, the mechanical engineering industry, safety technology, and the electronics industry, performance-determining products and services from HOERBIGER make the difference. With innovations for decarbonization and energy transition, HOERBIGER is already enabling change today for a better tomorrow. As majority shareholder, the HOERBIGER Foundation preserves the 129-year-old entrepreneurial heritage and guarantees stability, independence, and a future-oriented strategy.

HOERBIGER.COM

All rights reserved. Subject to change without notice © Copyright HOERBIGER 2025

