

Compressor conversion – the economical alternative



HOERBIGER



Heightened industry requirements entail higher demands on compressor performance

Trends such as predictive maintenance, new legislation regarding fuel quality as well as a varying demand for both different gas types and quantities keep changing prevalent industry requirements.

This is especially true for the following sectors:

■ **Process industry**

Refineries as well as oil and gas production
Petrochemical industry
Chemical industry

■ **Natural gas industry**

Gas transport
Gas gathering
Gas storage
Gas re-injection
LNG

■ **Technical gases**

Air separation
Syngas

The reasons and necessities for compressor conversions may be manifold and range from improved compressor availability, reliability and efficiency to changes in compressor capacity, adjustments to modified processes, adaptation to statutory requirements and the prevention of danger or serious damage.

What is more, compressor operators tend to increasingly concentrate on their core competences and thus look for a competent partner to manage their compressors.



HOERBIGER: Your partner for compressor conversions

As the world's leading manufacturer and provider of essential compressor components such as valves, control and sealing systems, HOERBIGER offers prime-quality products and services for a reliable, efficient and environmentally friendly operation of reciprocating compressors.

HOERBIGER feasibility studies provide a detailed check of the technical as well as economic efficiency of conversion projects.

Compressors are converted by means of engineered solutions which are based on comprehensive compressor expertise.

CE certification

- Risk analyses to ensure the compliance with security standards
- Use of CE-certified components

Compressor simulation

- Evaluation of performance and capacity
- Calculation of crank mechanism forces and evaluation of compressor part strength
- Evaluation of dynamics of compressor unit

Pulsation calculation

- Check of pulsations in accordance with generally accepted industry standards (API618).
- Recommendations for pulsation damper optimisation.

Component engineering and design

- Design of pressure-exposed components in accordance with pressure equipment standards
- Secure connections thanks to precisely engineered pre-loaded systems (piston rods/pistons)
- High-end strength checks by means of finite element methods (pistons)

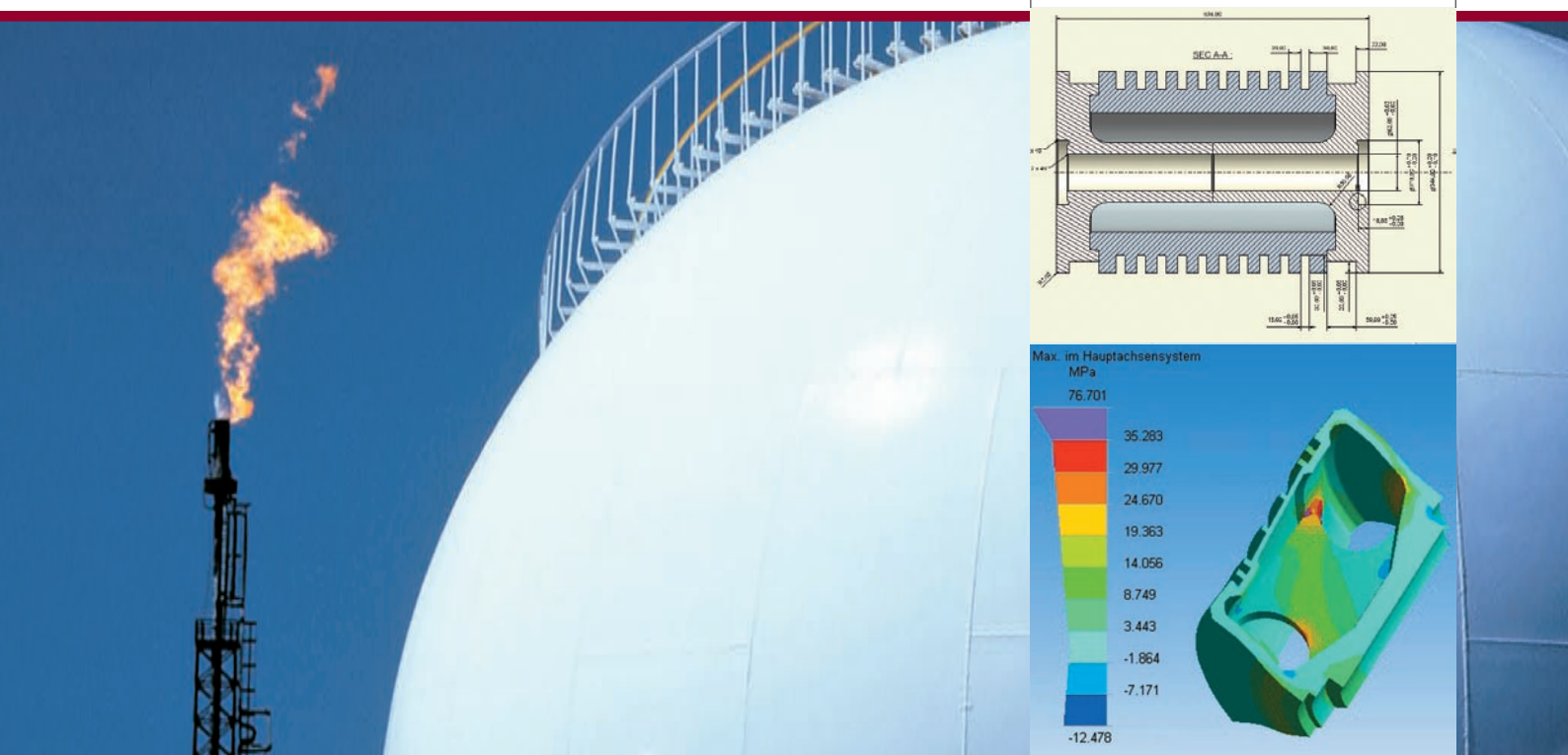
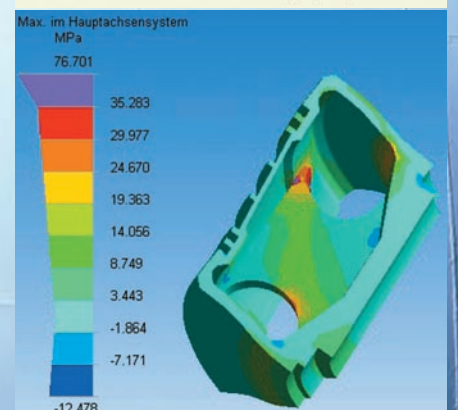
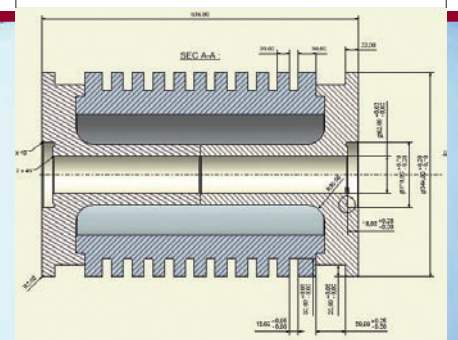
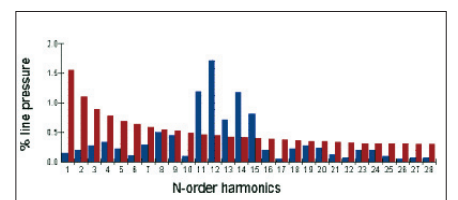
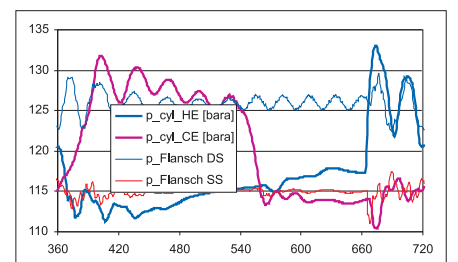
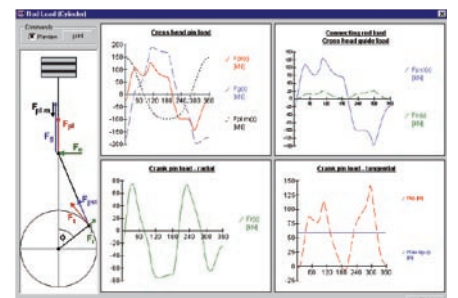
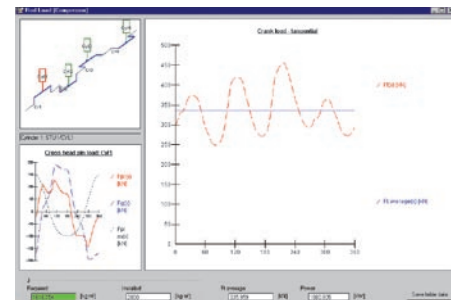

Customized engineering solutions for your compressor conversion

Optimised tribology for a higher reliability

Reasons for ring and packing failure or for increased piston rod wear may be manifold. Process conditions, compressor lubrication as well as the tribological properties of compressor parts that are subjected to high friction influence both wear part reliability and lifetime.

In this respect, HOERBIGER investigate the entire system, analyses all the influencing parameters, and develops complete solutions with regard to ring design and material, counterfaces and the lubrication of the tribological subsystems

- piston rings and liner
- main packing/ oil packing/ auxiliary packing and rod
- lubrication system (conversion from lube to non lube and vice versa).

Proven engineered solutions are among others:

- BOT packing rings: the design which distributes the gas load across all sealing ring pairs
- Thermosleeve packing: the packing housing with the heat transfer function
- OT oil wiper packing: the design for reducing oil leakage to almost nothing
- HY ring materials: proven and tailor-made materials for every application
- Piston rods and cylinder liners: high-quality standards for running faces and material strength.

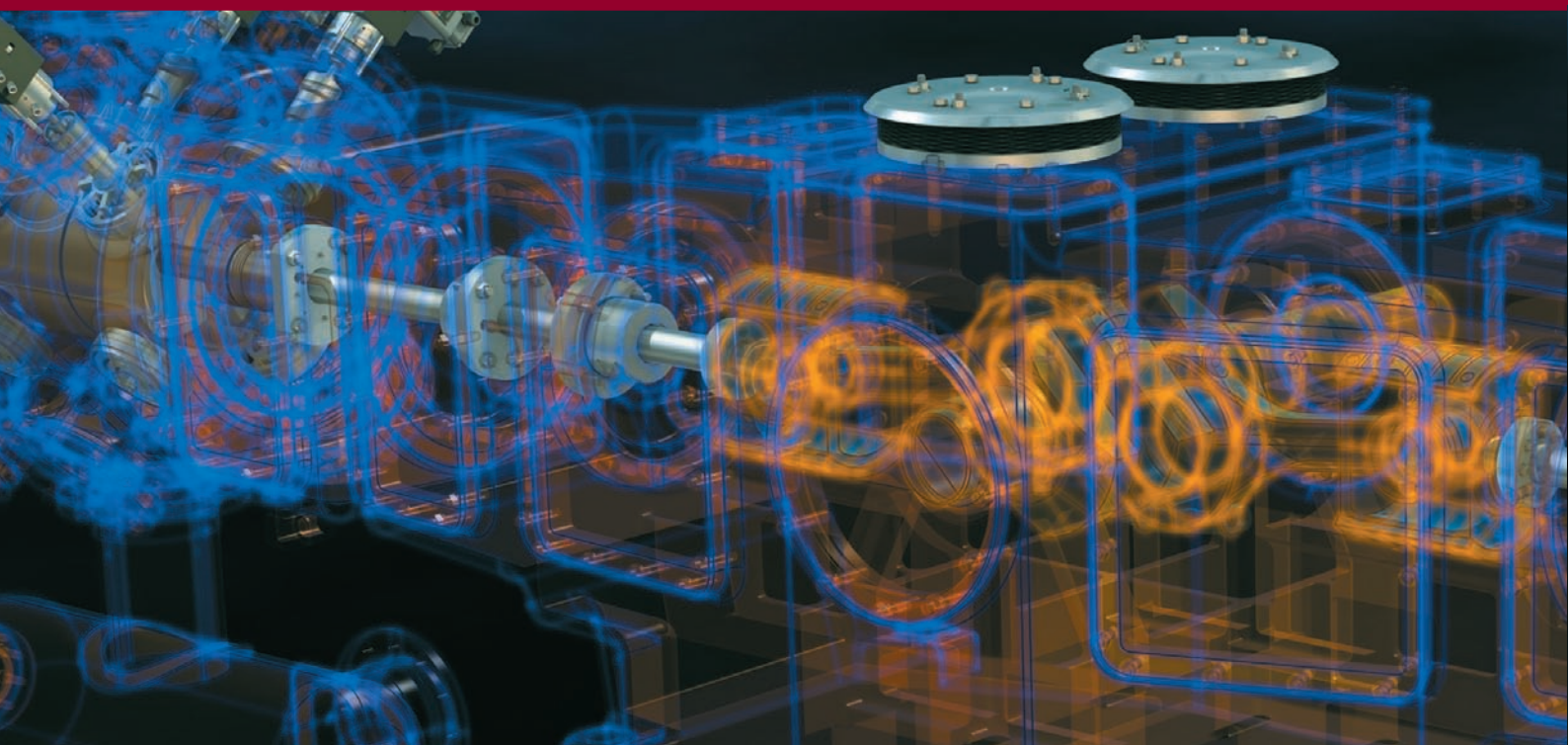

HydroCOM turn-key solutions for a better availability and efficiency

Nowadays HydroCOM control constitutes the prevalent industry standard in new compressors which need a stepless control. However, it is also possible to significantly increase efficiency in already installed compressors as well as to modernise their control systems.

HOERBIGER'S HydroCOM turn-key projects comprise:

- Compressor load calculations
- Pulsation calculations
- Standardisation of valve sets (actuator, cover, cage, valve)
- Definition and programming of control system
- Installation of the system as well as the hydraulic piping
- Start-up

Enhanced safety for men and machine

Due to ever increasing importance of HS&E matters (health, safety & environment) and increasing safety requirements for compressors (e. g. CE-certification, ATEX, etc.), compressors need to be equipped with respective safety features. For conversion projects, HOERBIGER thus offers

- Check of existing safety equipment and adaptation to the most recent regulations and standards
- Risk analysis
- CE-certification
- Load analysis and strength test.

Ever increasing performance requirements may exceed the stress limits of certain compressor parts.

In this respect, HOERBIGER offers

- Redesign of compressor parts
- Installation of explosion relief valves and check valves
- Online compressor monitoring of all safety-relevant operating parameters.

Capacity increase or adaptation to altered process conditions

With the adequate compressor and product engineering a simple modification may be sufficient to increase capacity and reliability or to adapt the compressor to a changed process.

Through calculation and redesign of

- cylinder bores
- liner geometry
- piston
- clearance volume, etc.

HOERBIGER, as an independent partner, will explore all possibilities in order to find the most cost-efficient solution with regard to return on investment.



HOERBIGER

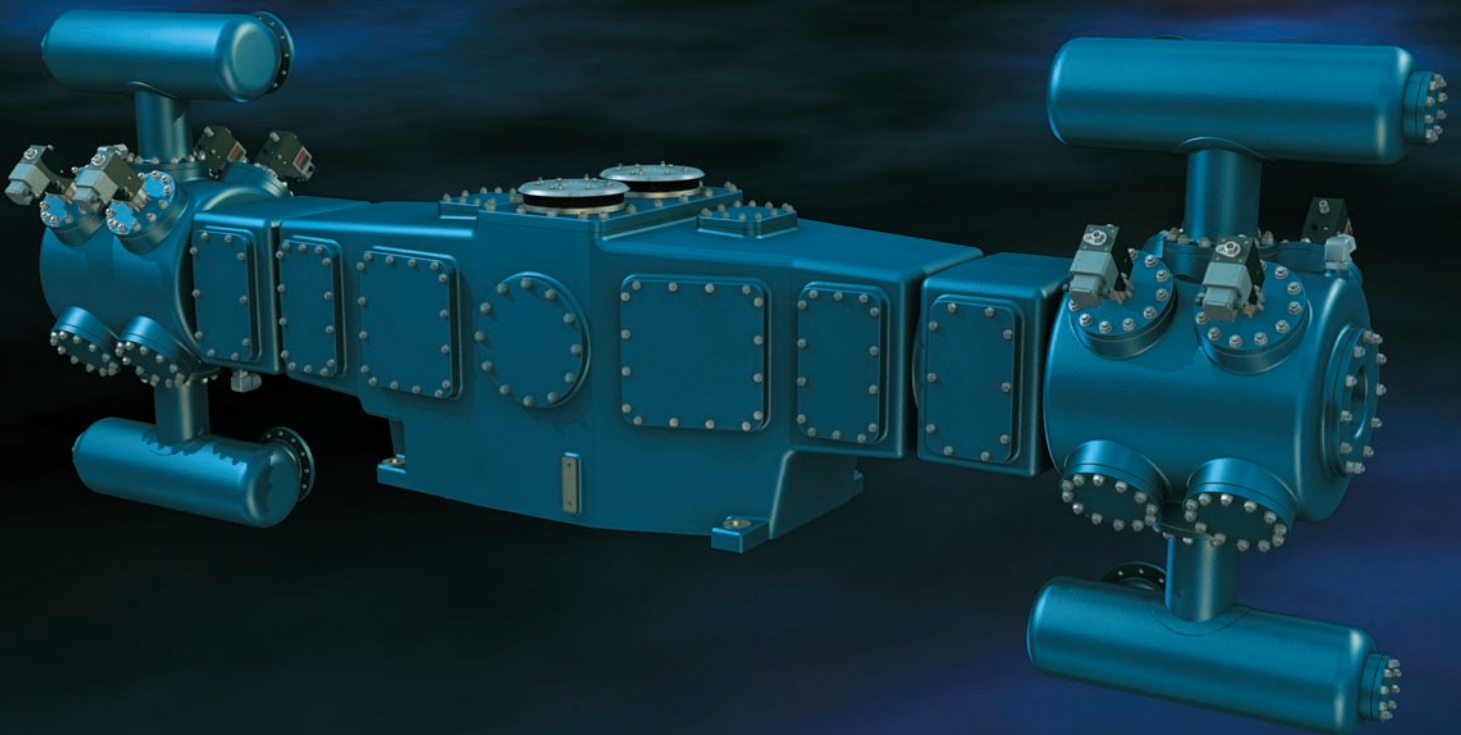



**Energy costs are a topical issue:
also when it comes
to the transport and storage
of natural gas.**

In many cases, gas storage compressors are equipped with clearance volume systems and other both complex as well as outdated control systems. Turn-key HydroCOM conversions of gas storage plants situated in Germany, Poland and Rumania have considerably increased the plants' flexibility for extracting or storing exact quantities of natural gas.

**These days: characterised
by an ever-increasing demand
for higher capacities**

HOERBIGER is currently investigating the feasible degree of capacity increase in refineries situated in France, Greece and Spain. By means of enlarging the diameter of the cylinder, for example, HOERBIGER can adapt compressors to the desired volumes.



Higher availability thanks to shorter response times

An Italian refinery was hit by an emergency. HOERBIGER managed to quickly supply converted compressors, which now compress hydrogen in the refinery's desulphurisation plant. When a compressor operating in an Algerian oil field suffered severe damage, HOERBIGER's services were essential in restoring the compressor's availability.



Flexibility at work – also for compressors: Old plants are converted to handle new processes and gases

Both old air and gas compressors may be used for the compression of new gases. Over the past four years, HOERBIGER managed to convert three air compressors that had been operating in one of Hungary's biggest chemical plants into hydrogen compressors.



HOERBIGER



Advantages of compressor conversion by HOERBIGER:

- ✓ Comprehensive compressor engineering
 - Compressor simulation
 - Compressor analysis
 - Engineered compressor components and systems
- ✓ Compressor know-how
- ✓ Feasibility analysis of conversion projects for technical and economic efficiency
- ✓ Turn-key projects with return on investment
- ✓ HOERBIGER full compressor service workshops – always near you
- ✓ Worldwide compressor references

www.hoerbiger-compression.com

HOERBIGER
because performance counts

Algeria · Argentina · Australia · Austria · Bolivia · Brasil · Brunei · Canada · China · Colombia · Croatia · Czech Republic · Egypt · Finland · France · Germany · Greece · Hungary · India · Indonesia · Israel · Italy · Japan · Kuwait · Libya · Lithuania · Malaysia · Mexico · Montenegro · Netherlands · New Zealand · Nigeria · Norway · Oman · Pakistan · Philippines · Poland · Portugal · Romania · Russia · Saudi Arabia · Serbia · Singapore · Slovakia · South Africa · South Korea · Spain · Sweden · Switzerland · Syria · Taiwan · Thailand · Turkey · United Arab Emirates · United Kingdom · United States of America · Venezuela · Vietnam